

Datawell
Intelligent Test Box
User's Manual



Datawell BV
oceanographic instruments

Service
Voltastraat 3
1704 RP Heerhugowaard
The Netherlands
☎ +31 72 571 8219
☎ +31 72 571 2950

Sales
Zomerluststraat 4
2012 LM Haarlem
The Netherlands
☎ +31 23 531 6053
☎ +31 23 531 1986

www.datawell.nl

April 7, 2009

Contents

1 Sequential discharge of battery strings by the ITB.....	5
2 Operation Fundamentals	6
3 Battery booster.....	6
4 Checking the status of the batteries via the transmitted battery status information.....	6
5 Checking the status of the batteries via the ITB in the hull.....	6
6 Replacing batteries	7

1 Sequential discharge of battery strings by the ITB

The batteries in the (Directional-) Waverider are grouped in one or more parallel strings of batteries. Each string contains 13, 15 or 16 batteries in series, depending on the type of buoy. In the standard configuration all strings and thus all batteries are simultaneously discharged. Straightforward design and optimal load distribution are obvious advantages of this configuration.

In case of an (unexpectedly) short buoy deployment it is more advantageous to discharge only a selected part of the batteries and leave the remaining batteries unused. In that case, refreshing of the batteries can be limited to the used batteries only. Sequential discharge of the strings is a pragmatic way to leave as many batteries unused as possible. In each string a switch is incorporated controlled by special switch-control-electronics.

The switches and control electronics are housed in the so called testbox. In this testbox the voltage of the individual battery strings can be checked. Furthermore, in case of the sensor based (Directional) Waverider, various parameters like pitch, roll, compass and accelerometers, can be monitored. The testbox, containing the standard testbox functionality and the control electronics plus switches is called the "Intelligent Test Box", or ITB for short.

In figure 1.1 below, the standard and ITB configuration is displayed.

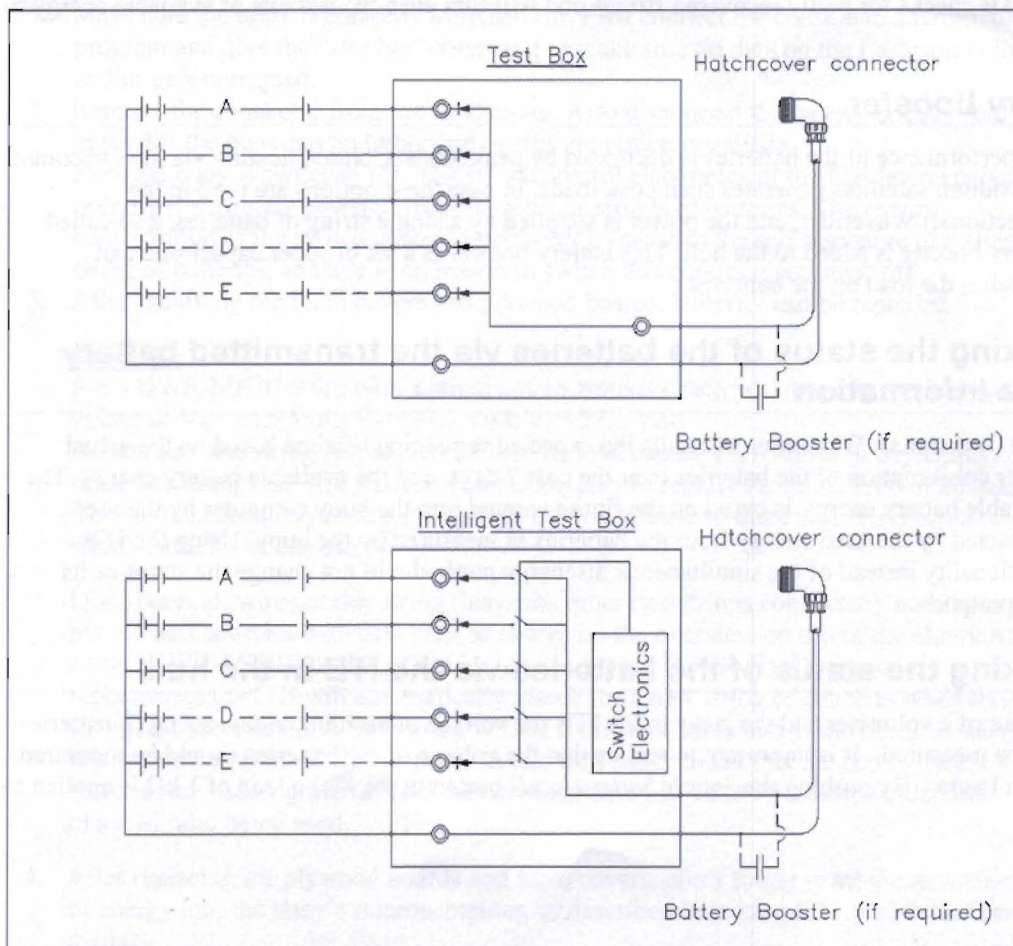

Figure 1.1

2 Operation Fundamentals

When the batteries are connected to the internal wiring of the buoy the ITB selects a first string of batteries. It is not required, that all strings are equipped with batteries. The ITB will automatically skip those strings.

When the buoy is switched on by means of inserting the connector between the hull and the hatch cover, the complete power consumption of the buoy is supplied by the string selected by the ITB. This remains until the string of batteries is depleted. In that case the ITB switches over to another, fresh, string of batteries and the string of depleted batteries is disconnected. Care is taken in the switching sequence to avoid power dips. The search sequence of the ITB is ABCDEABC..etc.

The batteries in each string are connected through coloured battery wires. Each string has its own wire colour. Notice that there is a difference in colouring between the DWR-MKIII 0.9m and DWR-G 0.9m battery strings. See table 2.1 below.

Table 2.1

DWR-MKIII 0.9m		DWR-G 0.9m	
String	Colour	String	Colour
A	Red	A	Brown
B	Orange	B	Red
C	Yellow	C	Orange
D	No longer used	D	Yellow
E	No longer used	E	Green

The ITB will use all available battery strings one by one. After all fresh strings have been used, the ITB checks for partly recovered strings and will turn even the last bits of available energy to use.

3 Battery booster

The performance of the batteries is decreased by peak loads. Communication via the Orbcomm and Iridium satellites generates such peak loads. In case these options are used in the (Directional) Waverider, and the power is supplied by a single string of batteries, a so called battery booster is added to the hull. This battery booster is a set of super capacitors, that smoothes the load on the batteries.

4 Checking the status of the batteries via the transmitted battery status information

The (Directional) Waverider transmits the expected remaining lifetime based on the actual power consumption of the batteries over the past 7 days, and the available battery energy. The available battery energy is based on the figure entered into the buoy computer by the user subtracted by the used energy from the batteries as measured by the buoy. Using the ITB functionality instead of the simultaneous discharge method will not change the status or its interpretation.

5 Checking the status of the batteries via the ITB in the hull

By use of a voltmeter and the jacks in the ITB the voltage of each individual string of batteries can be measured. It is important to realize that the voltage of the batteries should be measured when loaded. By pushing the "apply battery load" button in the ITB a load of 1 k Ω is applied to

each string of batteries for a period of 60 seconds. The battery load is active as long as the “load active” led is on.

By applying the load, the voltage of the batteries lowers. For a reliable diagnosis please wait until the reading of the voltmeter is fairly steady. In case the reading is not stable at the end of the load-period, the “*apply battery load*” button can be pushed again for an extra load cycle.

Via the discharge curve of the individual battery, the voltage of the string indicates the fraction of discharge, see table 5.1 below.

Table 5.1

Percentage Lifetime left	Single battery (Volt)	13 batteries per string (Volt)	15 batteries per string (Volt)	16 batteries per string (Volt)
100% (fresh)	1.55	20.2	23.3	24.8
75 %	1.4	18.2	21.0	22.4
50 %	1.3	16.9	19.5	20.8
25% (nearly empty)	1.1	14.3	16.5	17.6
< 25% (empty)	1.0	13.0	15.0	16.0

6 Replacing batteries

After measuring the voltages of each string and deciding to replace a single string of batteries, please, use the following steps:

1. Make sure the buoy is correctly switched off. First connect the console to a terminal program and give the “*stoplog*” command to make sure no data on the flashcard is lost and/or gets corrupted.
2. Remove the connector from the hatchcover. Also disconnect the battery booster (only present if the buoy has an Orbcomm or Iridium option installed).
Now the buoy is switched off. The switch control electronics of the ITB however isn't because it's directly powered from the various strings of batteries. The energy consumption of the switch control electronics is less than the self discharge of a single string of batteries, so there is no reason to switch this control electronics off.
3. After removing the foam covers and plywood boards, batteries can be replaced.

Example:

For a DWR-MKIII 0.9m with 3 strings of 15 batteries each you measure the following voltages: $V_A = 16.5$ Volt; $V_B = 23.3$ Volt; $V_C = 23.3$ Volt.

As you can see, string A (red) has 25% of its total capacity left and is nearly empty. The other two strings are still fresh so you decide only to replace string A. First of all mark the top of each battery of this string with a white marker so there will be no mistake which batteries to dispose of.

Disconnect all wires of this string (leave the other two strings connected), and replace the marked batteries with new ones as shown on the overview on top of the aluminium cover (DWR-MKIII) or one of the 2 plywood boards (DWR-G). During this replacement the ITB will automatically search for a new string of batteries when this string is disconnected. A new string will be found and attributed as the string in use (in this case string B is the first in row). In this way it is avoided that the newly placed batteries are used right away and the non-used string of batteries become older and older without being used.

4. After replacing the plywood boards and foam covers, don't forget to set the new amount of energy into the buoy's microcomputer, as described in section 5.11.5 of the reference manual.